

JOC341

Common Mode Transient Immunity at Low Level Output	CML	I _F =0mA V _{CC} =30V, T _a =25 , V _{O(max)} =1V V _{CM} =1000Vpp	±35	-	-	kV/μs
--	-----	---	-----	---	---	-------

All Typical values at T_a=25

: Input signal (f=25kHz,duty=50%, tr=tf=5ns or less). C_L is less than 15 pF which includes probe and stray wiring capacitance.

: C_{MH} is the maximum rate of fall of the common mode voltage that can be sustained with the output voltage in the logic high state (V_O = 26V).

: C_{ML} is the maximum rate of rise of the common mode voltage that can be sustained with the output voltage in the logic low state (V_O = 1V).

Characteristics	Symbol	Min.	Typ.	Max.	Unit
Input On-state Current	I _{F(ON)}	6.5	-	10	mA
Input Off-state Voltage	V _{F(OFF)}	0	-	0.8	V
Supply Voltage	V _{CC}	15	-	30	V
Operating Frequency	f	-	-	25	kHz

: The recommended operating conditions are given as a design guide necessary to obtain the intended performance of the device. Each parameter is an independent value. When creating a system design using this device, the electrical characteristics specified in this datasheet should also be considered.

: A ceramic capacitor(0.1μF) should be connected between pin 6 (V_{CC}) and pin 4 (GND) to stabilize the operation of a high i m biln / e ed i b

	<p>JOC : Company Abbr. 341 : Part Number VYAWW : LOT NO.</p>
<p>JOC – Company Abbr. 341 – Part Number Y – Lead Form Option Z – Tape and Reel Option (T1/T2) G – Green V – VDE Option (V or None)</p>	
T1/T2	3000 Units/Reel

FIG.1: Forward Current vs. Forward Voltage



FIG.2: Max. Allowable LED Forward Current vs. Ambient Temperature

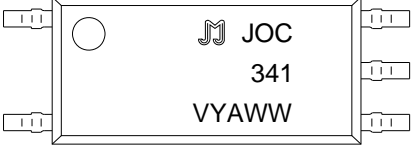
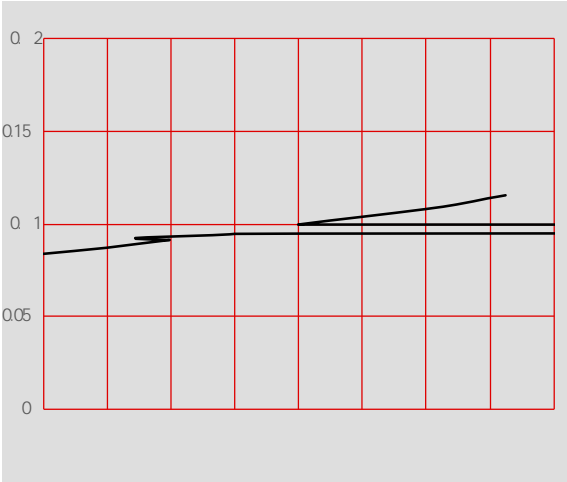

FIG.13: Propagation Delay Time vs. Supply Voltage

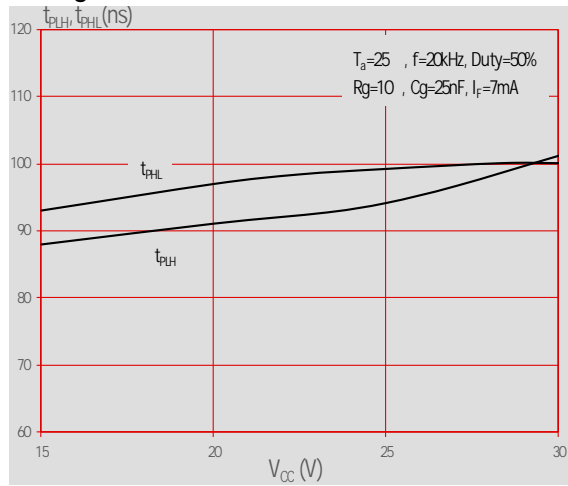
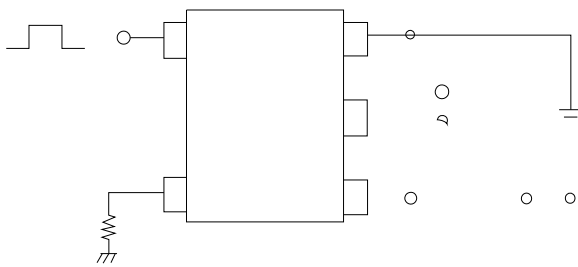
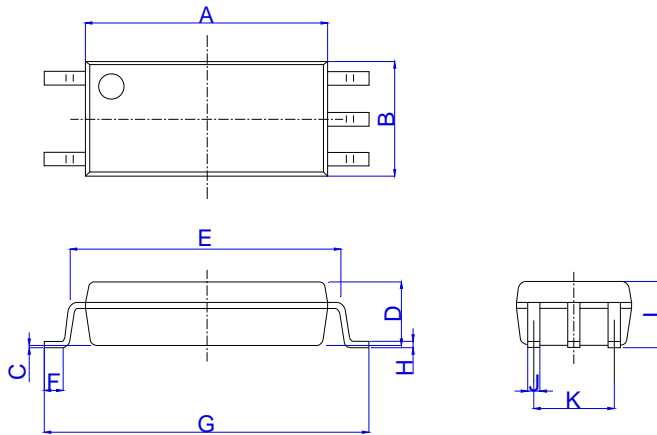
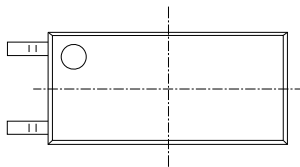

FIG.14: Switching Time Test Circuit and Waveform





Ref.	Dimensions					
	Millimeters			Inches		
	Min.	Typ.	Max.	Min.	Typ.	Max.
A	7.40		7.80	0.291		0.307
B	3.40		3.80	0.134		0.150
C	0.00		0.20	0.000		0.008
D	1.80		2.20	0.071		0.087
E	8.10		8.70	0.319		0.343
F	0.40		1.00	0.016		0.039
G	9.90		10.50	0.390		0.413
H	0.10		0.30	0.004		0.012
I	1.80		2.40	0.071		0.094
J	0.25		0.55	0.010		0.022
K	2.29		2.79	0.090		0.110



Ref.	Dimensions					
	Millimeters			Inches		
	Min.	Typ.	Max.	Min.	Typ.	Max.
A	7.40		7.80	0.291		0.307
B	3.40		3.80	0.134		0.150
C	0.00		0.20	0.000		0.008
D	1.80		2.20	0.071		0.087
E	8.10		8.70	0.319		0.343
F	0.55		1.15	0.022		0.045
G	10.78		11.38	0.424		0.448
H	0.06		0.26	0.002		0.010
I	1.80		2.40	0.071		0.094
J	0.25		0.55	0.010		0.022
K						

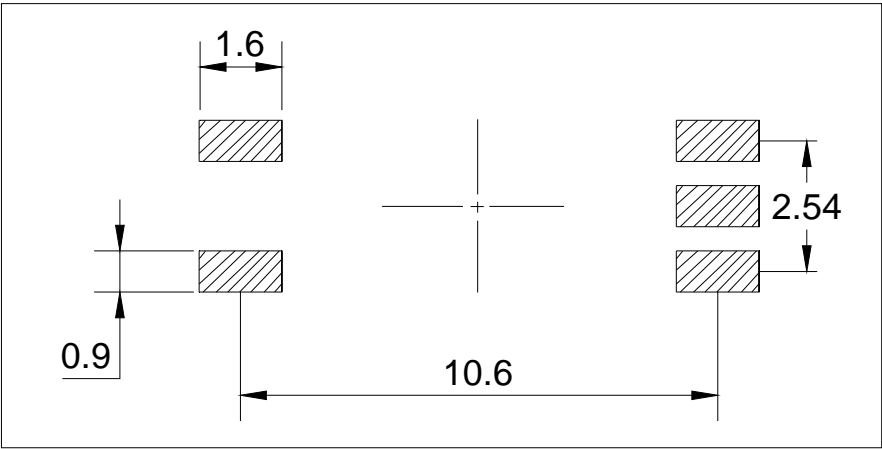



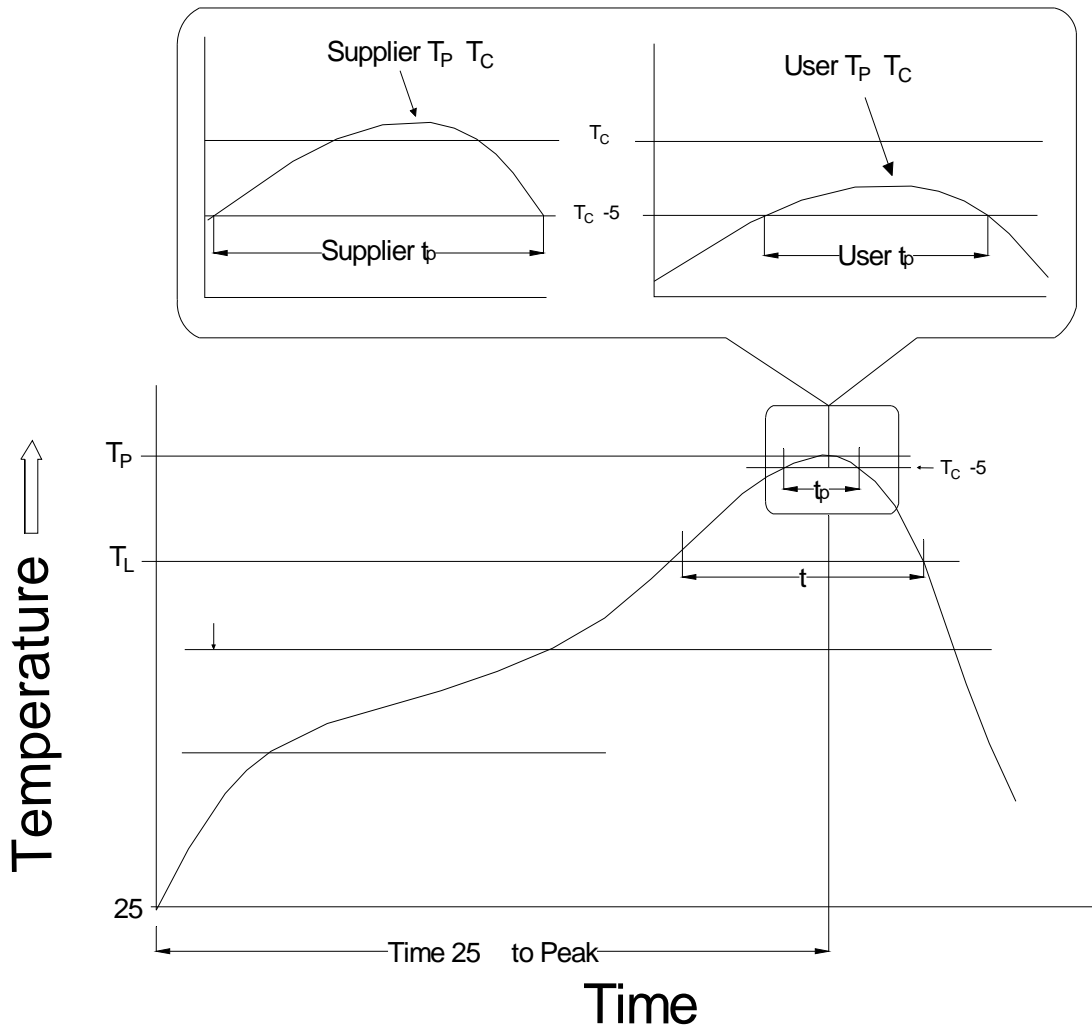

Note:

1. Reflow soldering is recommended at the temperatures and times shown, no more than three times.
2. Avoid direct contact between the epoxy body and any tools or surfaces exceeding its maximum