

	Time to Logic Low						
	Propagation Delay Time to Logic High	TPLH	$I_F=7mA, C_L=15pF$	-	55	100	ns
	Common Mode Transient Immunity at Logic High	CM _H	$I_F=0mA,$ $V_{CM}=1000Vpp,$ $C_L=15pF,$ $V_{CC}=5V$	20	-	-	kV/ μs
	Common Mode Transient Immunity at Logic Low	CM _L	$I_F=7mA,$ $V_{CM}=1000Vpp,$ $C_L=15pF,$ V_{DD}	\bar{A}	CM		

ORDERING INFORMATION

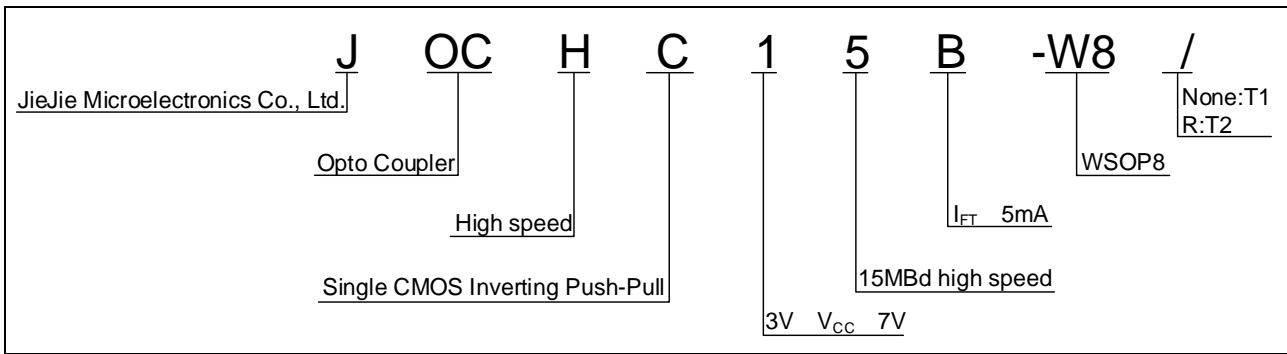

Packing Quantity	
Option	Quantity

MARKING

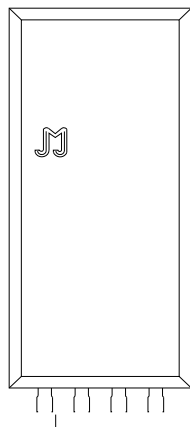

Characteristics Curves

FIG.1: Forward Current vs. Forward Voltage

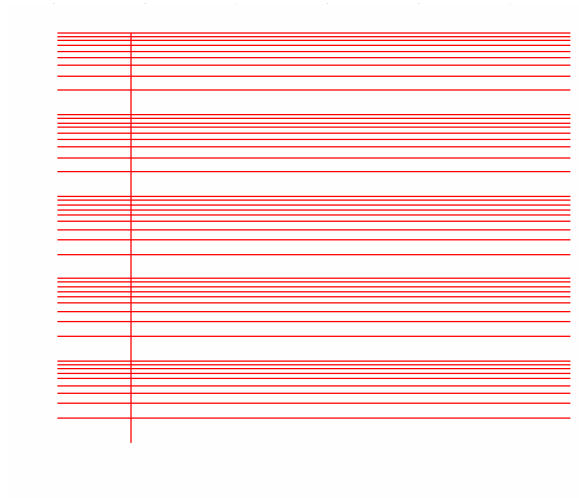

FIG.2: Max. Allowable LED Forward Current vs. Ambient Temperature

FIG.7: Propagation Delay vs. Ambient Temperature

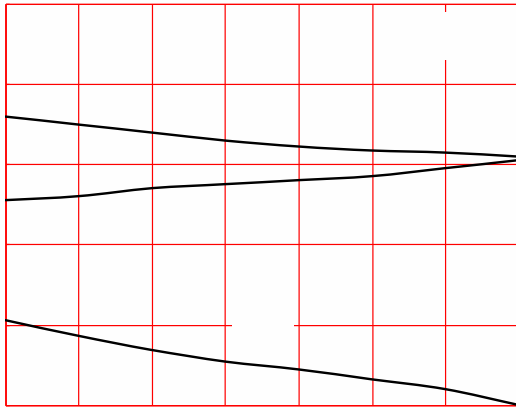
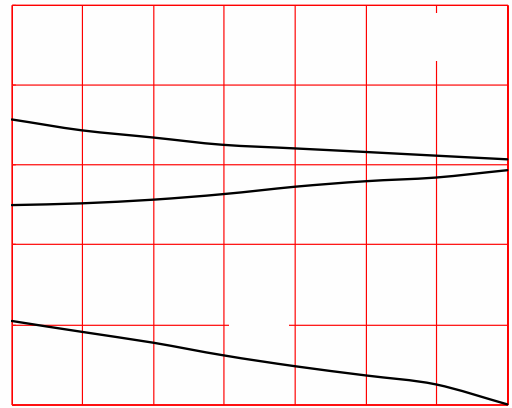

FIG.8: Propagation Delay vs. Ambient Temperature



TEST CIRCUITS

Fig.9: Test Circuits for TPHL, TPLH, tr, tf

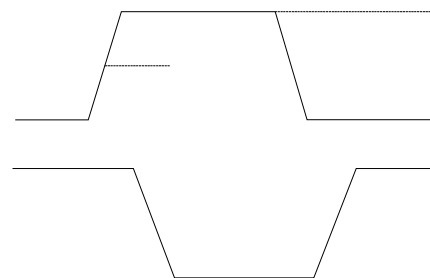
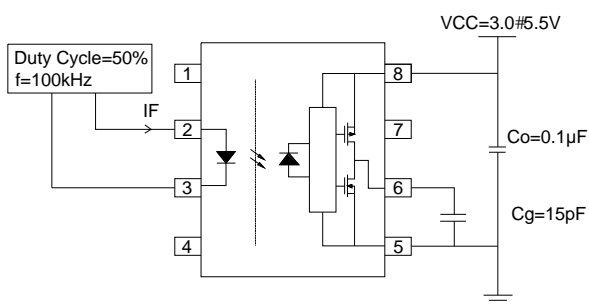
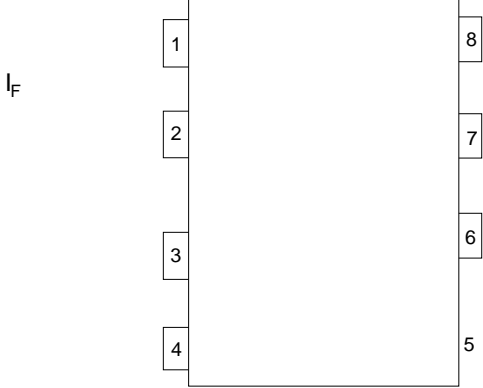

Fig.10: CMTI Test Circuit Recommendations



RECOMMENDED SOLDER MASK (Dimensions in mm unless otherwise stated)



REFLOW INFORMATION

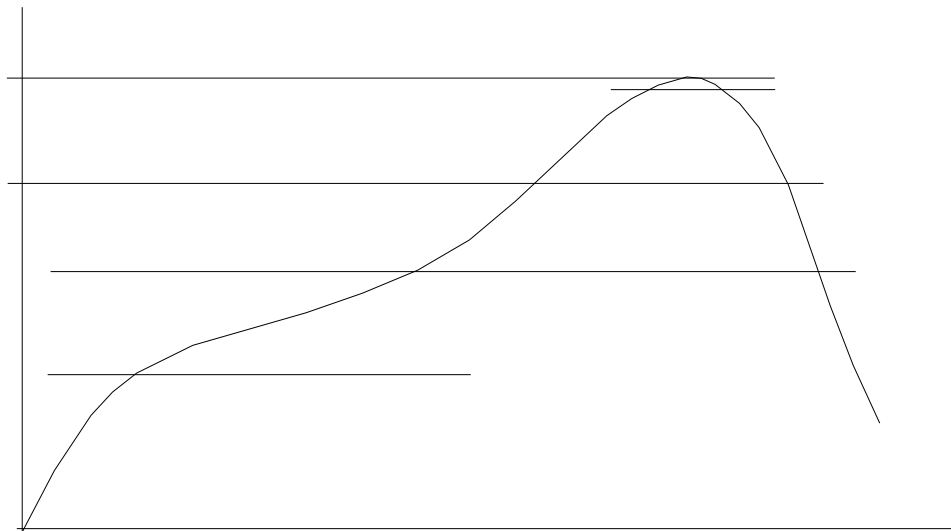
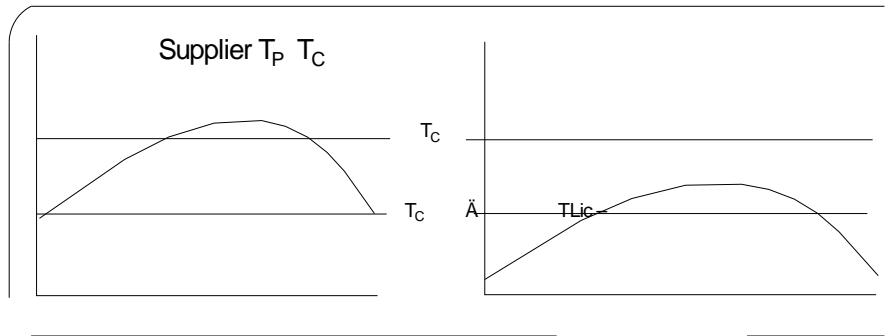

Note:

1. Reflow soldering is recommended at the temperatures and times shown, no more than three times.
2. Avoid direct contact between the epoxy body and any tools or surfaces exceeding its maximum storage temperature.
3. Application of pressure on the epoxy body is prohibited at elevated temperatures. In specific scenarios, any applied force must not exceed 2.5N.
4. Ensure the component has cooled to ambient temperature before proceeding with any subsequent manufacturing steps.
5. The component has a shelf life of one year when stored under standard conditions.
6. Recommend storage Temp.: 0~40°C;
Recommend storage humidity: <60%;
MSL level: MSL 1

Information furnished in this document is believed to be accurate and reliable. However, Jiangsu JieJie Microelectronics Co., Ltd. assumes no responsibility for the consequences of use without consideration for such information nor use beyond it. Information mentioned in this document is subject to change without notice, apart from that when an agreement is signed, Jiangsu JieJie complies with the agreement.

Products and information provided in this document have no infringement of patents. Jiangsu JieJie assumes no responsibility for any infringement of other rights of third parties which may result from the use of such products and information. This document supersedes and replaces all information previously supplied.

is a registered trademark of Jiangsu JieJie Microelectronics Co., Ltd.

Copyright © 2026 Jiangsu JieJie Microelectronics Co., Ltd. All rights reserved.