

DESCRIPTION:

The JORX213 series combine an AlGaAs infrared emitting diode as the emitter which is optically coupled to a monolithic silicon zero-cross photo triac to drive a power triac in a plastic DIP7 package with different lead forming options. The products are widely used in solenoid/valve controls, lighting controls, motor controls, temperature controls, static AC power switches, solid state relays, interfacing microprocessors to 265 V_{AC} peripherals.

MAIN FEATURES

- High isolation 5000 Vrms
- DC input with triac output
- Operating temperature range - 40°C to 85 °C
- REACH & RoHS compliance
- MSL class 2
- HBM: H3A; MM: M4
- CQC approved
- VDE approved
- UL approved

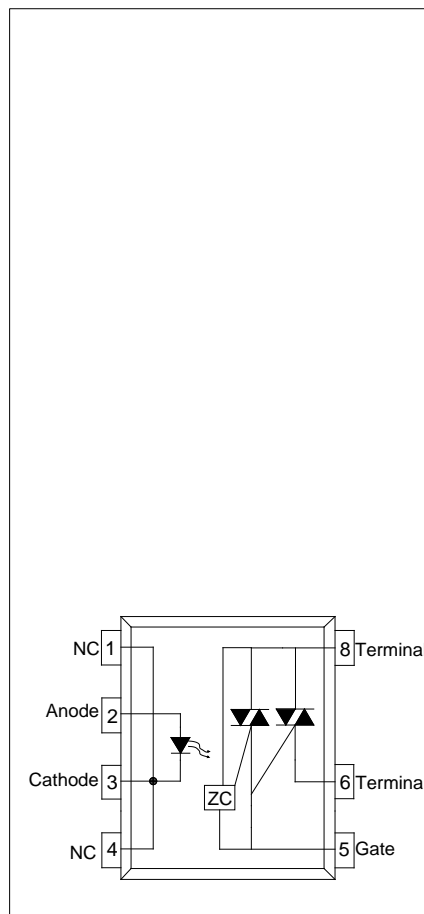

ABSOLUTE MAXIMUM RATINGS (Temperature=25°C)

Parameter		Symbol	Value	Unit	
Input	Forward Current	I _F	60	mA	
	Peak Forward Current	I _{FP}	1 ⁷	A	
	Reverse Voltage	V _R	6	V	
Output	Repetitive peak off-state voltage	V _{DRM}	600	V	
	Repetitive peak off-state voltage	V _{RRM}	600	V	
	Critical rate of rise of on-state current	di/dt	100	A s	
	On-state RMS Current	JOR0213	I _{T(RMS)}	0.3	A
		JOR1213		0.6	
		JOR2213		0.9	
JOR3213		1.2			
Non repetitive surge	JOR0213	I _{TSM}	3	A	

	peak on-state current (full cycle , $t_p=20ms$)	JOR1213		6	
		JOR2213		9	
		JOR3213		12	
Isolation Voltage		V_{iso}		5000 ⁸	Vrms
Operating Temperature		T_{opr}		-40~85	
Storage Temperature		T_{stg}		-40~125	
Soldering Temperature		T_{sol}		260 ⁹	

NOTE1 100 μs pulse, 100Hz frequency

NOTE2 AC for 1minute, R.H.=40~60%

NOTE3 For 10seconds

ORDERING AND MARKING INFORMATION

MARKING INFORMATION > K @ 0 P K € R D E R I N G I N F O R M A T I O N

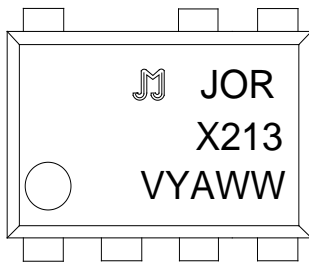

Characteristics Curves

FIG.1: Forward Current vs. Ambient Temperature



FIG.2: On-state Terminal Current vs. Ambient Temperature

TEST CIRCUITS

FIG.11: Test Circuits of Turn On Time

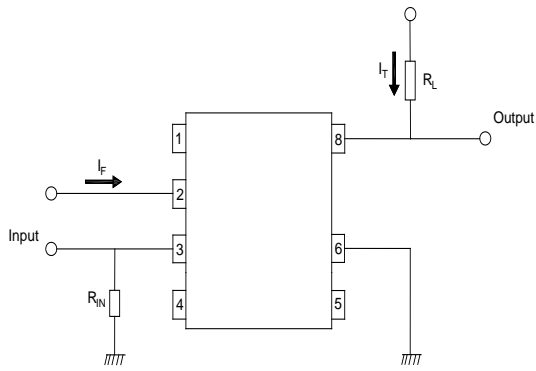
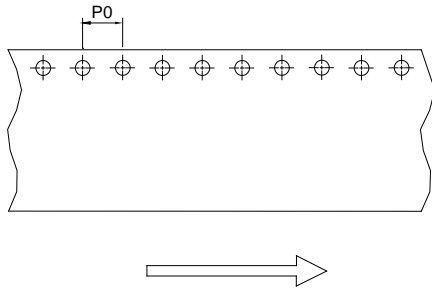
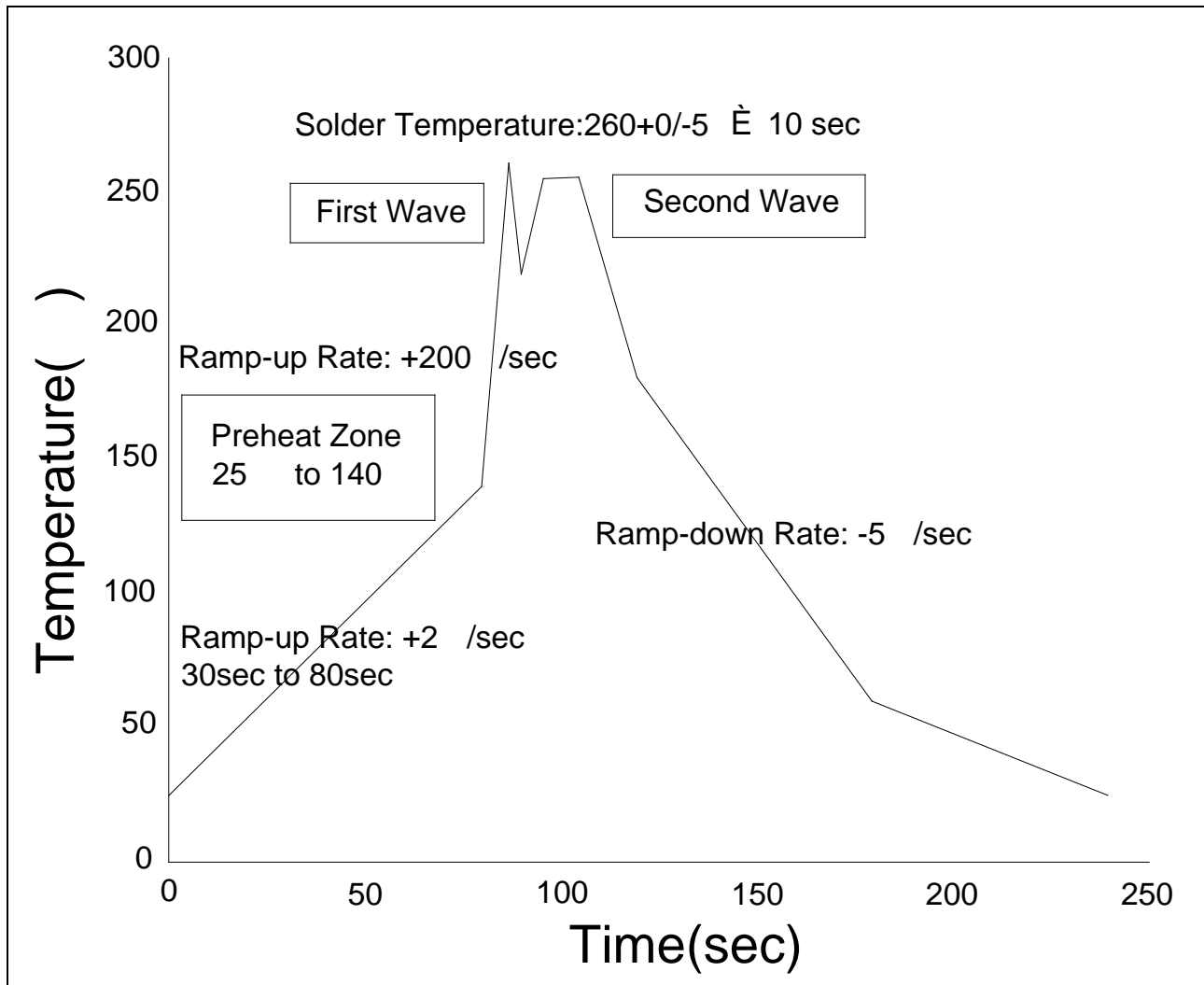

FIG.12: Waveforms of Turn On Time

CARRIER TAPE SPECIFICATIONS Dimensions in mm unless otherwise stated



WAVESOLDERING



HAND SOLDERING BY SOLDERING IRON

Soldering Temperature	360± 5
Soldering Time	3s max.

Document Revision History

Date	Revision	Changes
Feb.21, 2025	A.1.0	Last update
Nov.7, 2025	A.1.1	Add (dV/dt)c
Feb.27, 2026	A.1.2	Revise Package Dimension

Information furnished in this document is believed to be accurate and reliable. However, Jiangsu JieJie Microelectronics Co., Ltd. assumes no responsibility for the consequences of use without consideration for such information nor use beyond it. Information mentioned in this document is subject to change without notice, apart from that when an agreement is signed, Jiangsu JieJie complies with the agreement.

Products and information provided in this document have no infringement of patents. Jiangsu JieJie assumes no responsibility for any infringement of other rights of third parties which may result from the use of such products and information. This document supersedes and replaces all information previously supplied.

is a registered trademark of Jiangsu JieJie Microelectronics Co., Ltd.

Copyright © 2026 Jiangsu JieJie Microelectronics Co., Ltd. All rights reserved.